

I 40A

Peso Kg/m 0.30  
Weight Kg/m 0.30

Dimension H on request  
Dimension L on request

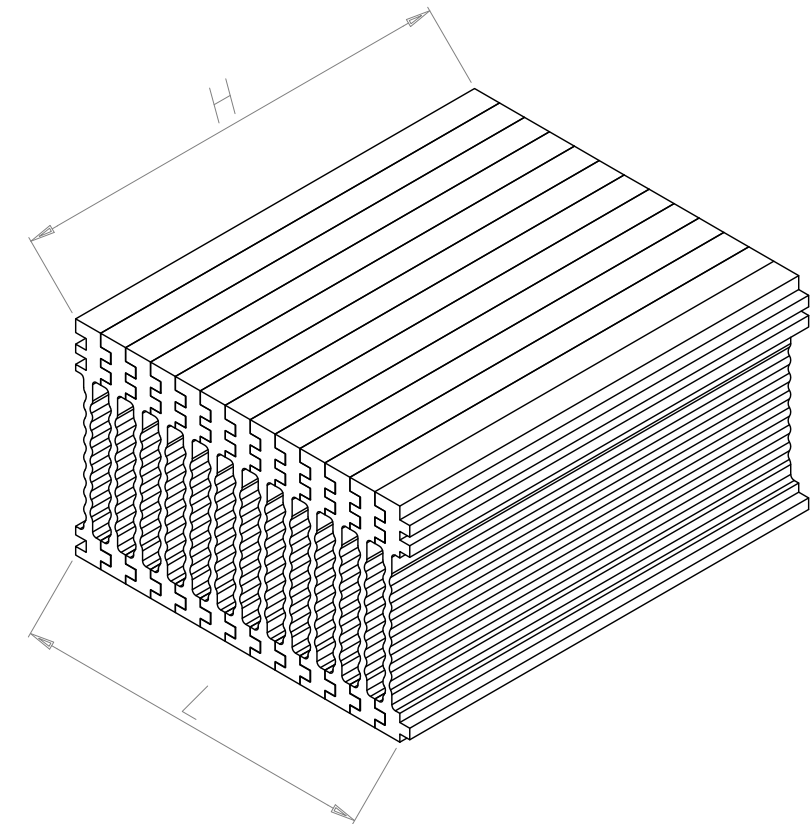
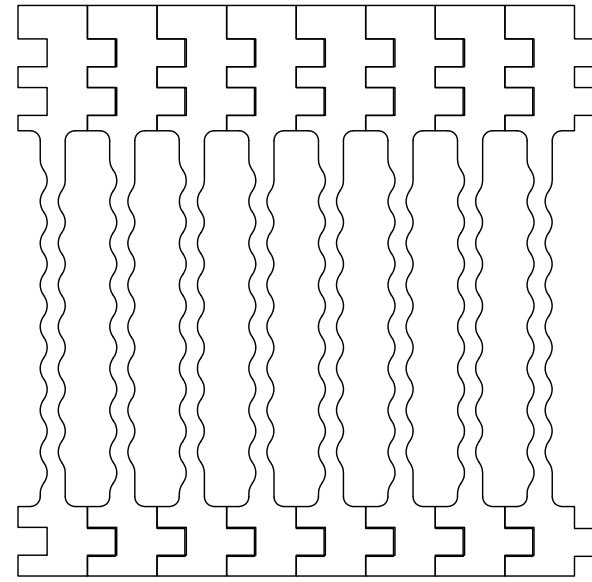
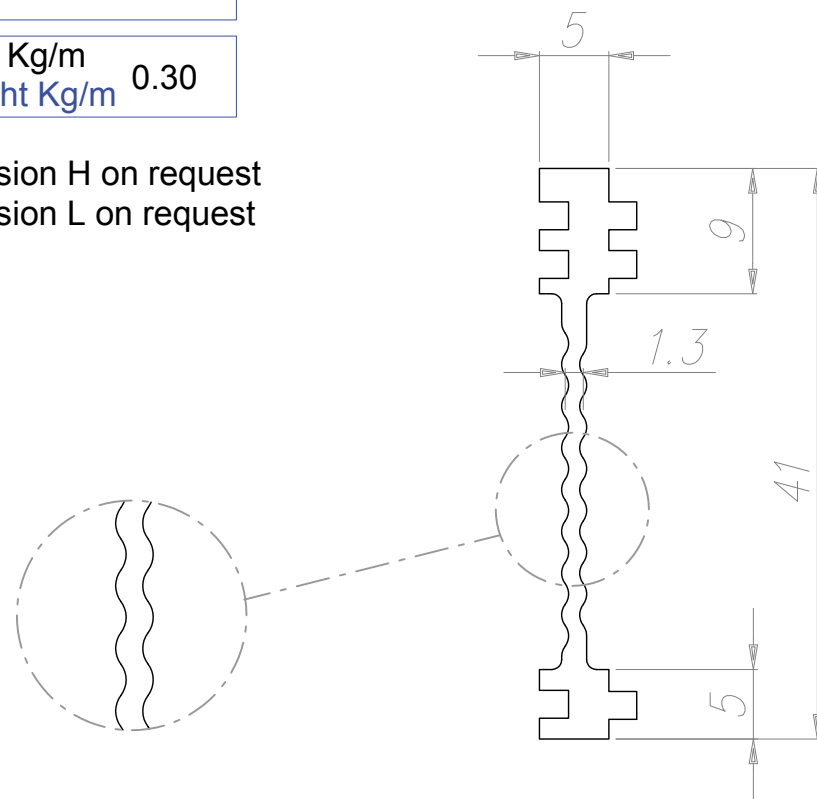

TECNOAL  
BOLOGNA - ITALY

DATA SHEET	PART NUMBER	I 40x80/150	I	L	H
			40	80	150

PROVA TEST	CARICO PRINCIPALE MAIN POWER LOAD W	CARICO SECONDARIO MINOR POWER LOAD W	VENTOLA 1 FAN 1 TYPE 40x40x20 DC	VENTOLA 2 FAN 2 TYPE 40x40x20 DC	ΔT °C	RT °C/W	VELOCITA' USCITA ARIA OUTGOING AIR SPEED m/sec	D.D.P. mm H <sub>2</sub> O
1	200	50	*	*	70.5	0.2820	2.5	
2	242		*	*	73.0	0.3016	2.5	
3	242		*		75.5	0.312	1.5	1.8
4	200	50	*		74.0	0.2960	1.5	1.8

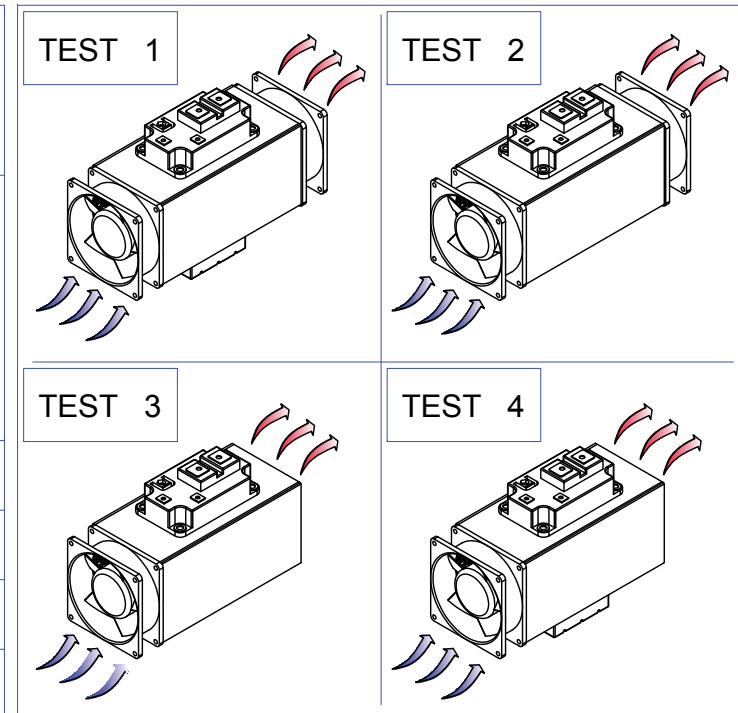

ALL SIZES ARE SUBJECT THE TOLERANCE OF EXTRUSION

UNLESS OTHERWISE INDICATED, PIECES NOT IN COMPLIANCE WITH THE GENERAL PRESCRIBED TOLERANCES SHOULD NOT AUTOMATICALLY BE REFUSE WHEN THE FUNCTIONALITY OF THE PIECES HAS NOT BEEN COMPROMISED.

TUTTE LE DIMENSIONI SONO SOGGETTE ALLE TOLLERANZE DI ESTRUSIONE

SALVO INDICAZIONE CONTRARIA I PEZZI NON CONFORMI ALLE TOLLERANZE GENERALI PRESCRITTE NON DEVONO ESSERE AUTOMATICAMENTE RIFIUTATI QUANDO LA FUNZIONALTA' DEL PEZZO NON RISULTA COMPROMESSA.