

I 125H

Peso Kg/m 1.21
Weight Kg/m

Dimension H on request
Dimension L on request

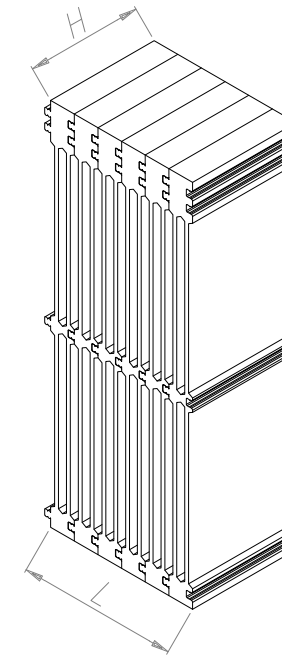
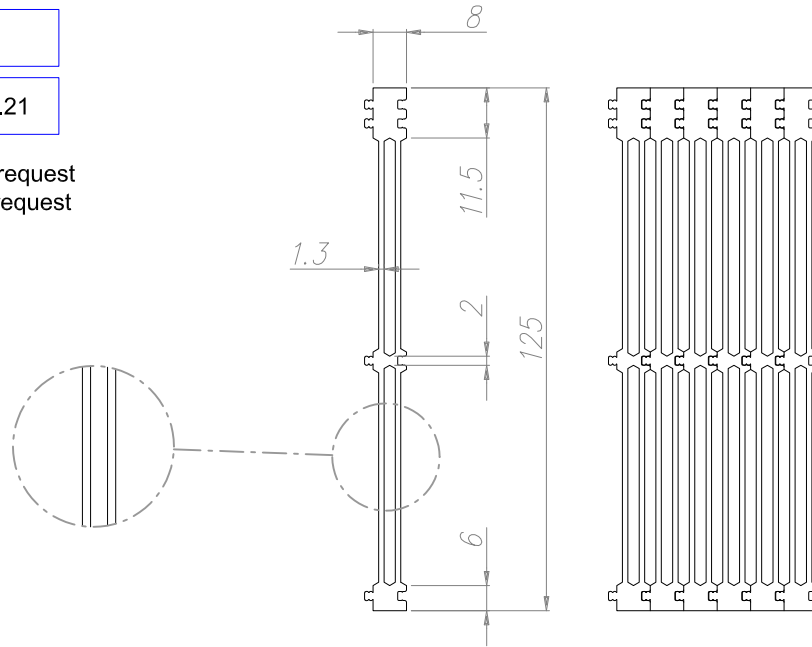

TECNOAL
BOLOGNA - ITALY

| | | | | | |
|------------|-------------|----------------|-----|-----|-----|
| DATA SHEET | PART NUMBER | I 125Hx120/300 | I | L | H |
| | | | 125 | 120 | 300 |

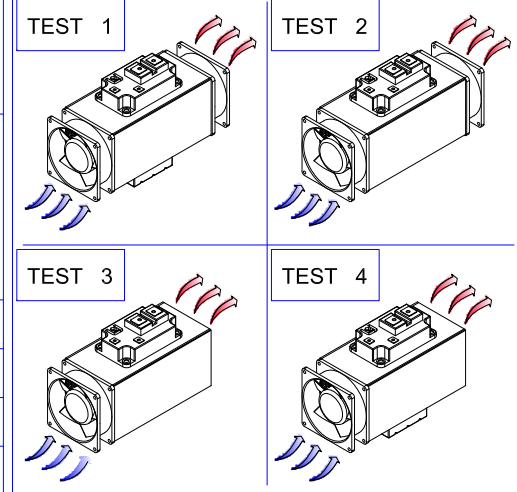

| PROVA TEST | CARICO PRINCIPALE MAIN POWER LOAD W | CARICO SECONDARIO MINOR POWER LOAD W | VENTOLA 1 FAN 1 TYPE 120x120x40 DC | VENTOLA 2 FAN 2 TYPE 120x120x40 DC | ΔT °C | RT °C/W | VELOCITA' USCITA ARIA OUTGOING AIR SPEED m/sec | mm H ₂ O |
|------------|---|--|---|---|----------|------------|--|---------------------|
| 1 | --- | --- | * | * | -- | --- | -- | |
| 2 | 835 | | * | * | 26.6 | 0.031 | 7.5 | |
| 3 | 835 | | * | * | 31.5 | 0.037 | 5.0 | 3.9 |
| 4 | --- | --- | * | * | -- | --- | -- | -- |

ALL SIZES ARE SUBJECT THE TOLERANCE OF EXTRUSION

TUTTE LE DIMENSIONI SONO SOGGETTE ALLE TOLLERANZE DI ESTRUSIONE

UNLESS OTHERWISE INDICATED, PIECES NOT IN COMPLIANCE WITH THE GENERAL PRESCRIBED TOLERANCES SHOULD NOT AUTOMATICALLY BE REFUSE WHEN THE FUNCTIONALITY OF THE PIECES HAS NOT BEEN COMPROMISED.

SALVO INDICAZIONE CONTRARIA I PEZZI NON CONFORMI ALLE TOLLERANZE GENERLI PRESCRITTE NON DEVONO ESSERE AUTOMATICAMENTE RIFIUTATI QUANDO LA FUNZIONALTA' DEL PEZZO NON RISULTA COMPROMESSA.